

## BWA 200 – for robot-controlled process automation

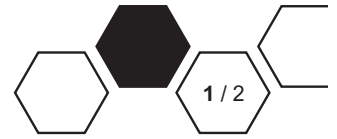

Your benefit – a robot tightening system for several assembly jobs with different screw geometries.

Increases the flexibility of the assembly and the possible variants in your station.

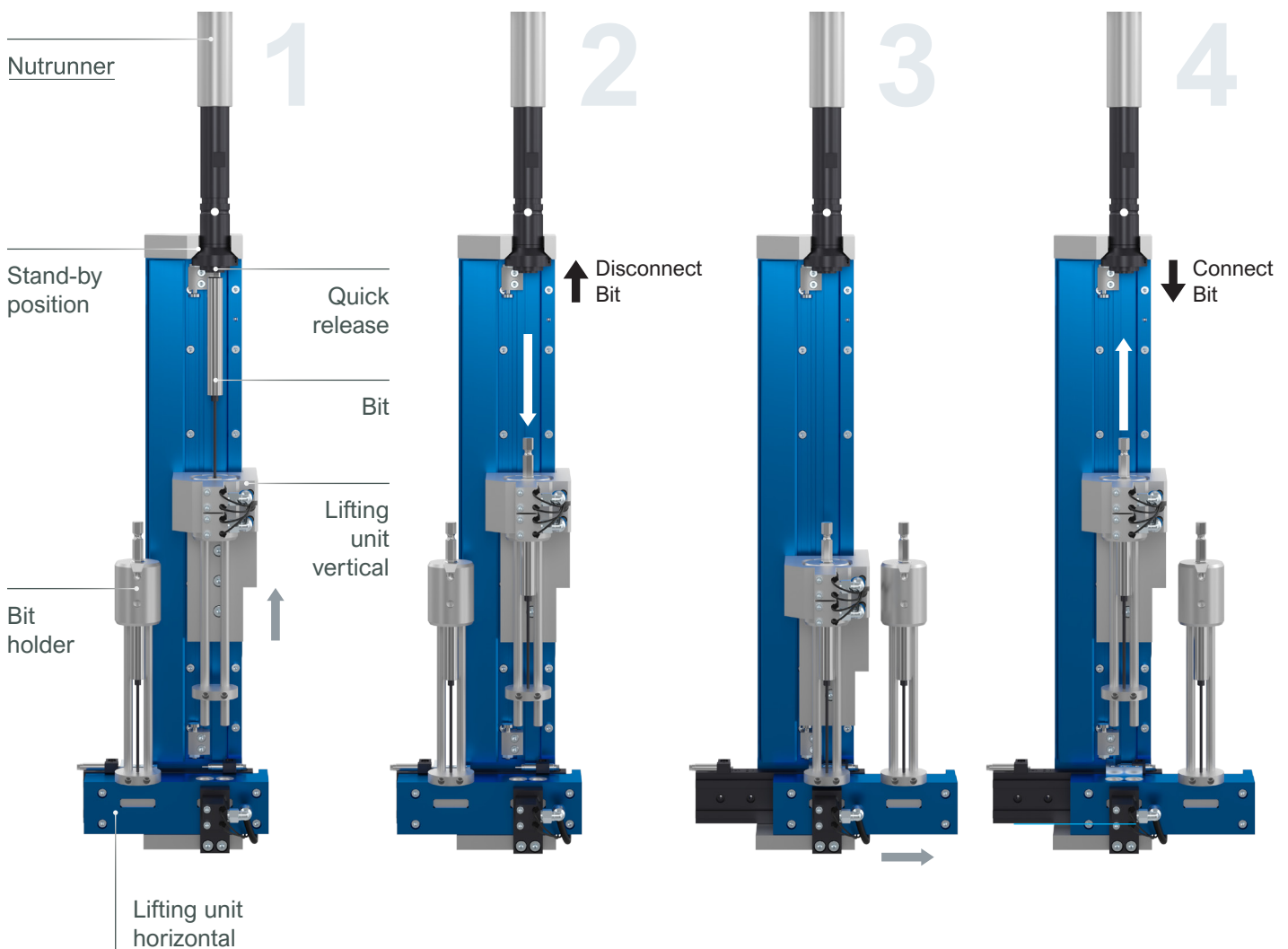

### Function

- (1) The robot moves the nutrunner to the bit changing machine and places it in the stand-by position. The vertical lifting unit moves up and the robot disconnects the bit by moving up.
- (2) Thereby the bit is taken out of the quick release and picked up from the bit holder. The lifting unit moves down, places the bit holder at the dedicated tool place and goes into change position.
- (3) The horizontal lifting unit moves to the bit which is needed for the screw connection. The vertical lifting unit moves down and picks up the bit holder.
- (4) The vertical lifting unit moves up and the robot connects the bit to the quick release on the nutrunner.



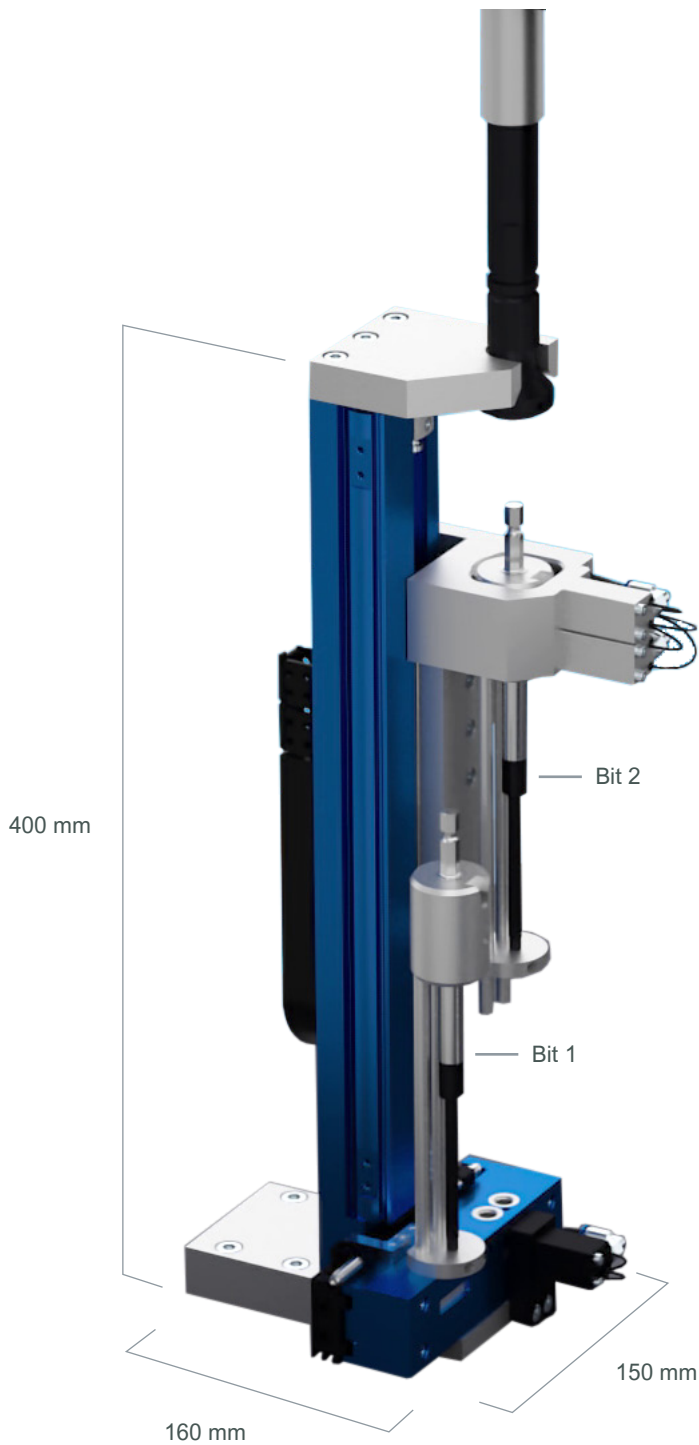
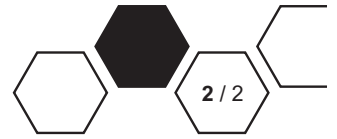

### Facts and Features

<b>Height:</b>	400 mm
<b>Width:</b>	150 mm
<b>Depth:</b>	160 mm
<b>Weight:</b>	approx. 2,5 kg
<b>Operating pressure:</b>	max. 6 bar

2 Bit holders (standard), expandable

Bit holder modular customisable to different bit geometries, max. bit length 150 mm

